

An Interview with
Regis Melizzi,
Instrument Team
Manager at Mobidiag

Q Can you explain Mobidiag's role in the fight against the COVID-19 virus?

Mobidiag is positioned to answer the need in the diagnostic aspect of the fight. The newly released Novodiag[®] COVID-19 test operates using the 'sample-in, result-out' Novodiag[®] system that allows for rapid detection of the SARS-CoV-2 virus, responsible for coronavirus infection, in about one hour. It's a fully automated machine and closed system that can protect laboratory staff from potential contamination. It's very user-friendly and designed for use in high risk and hard to reach areas without the need for highly trained personnel.

Q How did you come to the idea of implementing linear actuators in the Novodiag[®] instrument?

Novodiag integrates numerous biological functions which require motion specific elements within the instrument. These tasks are normally performed by an operator and our goal was to reproduce the various motions in an automated manner. As talking about motion often means talking about actuators, when the need for specific strokes, specific forces at specific speeds is established, it points in the direction of stepper motor-based solutions, and its integration within the Novodiag. Doing so, we are not re-inventing the diagnostic process itself (sample prep, PCR, hybridization). We intend to make it accessible to any operator, and to speed it up so he/she can focus on other operations. In addition, Novodiag allows to work with much smaller volume of fluids than when manually performed, and the sample preparation is done within the instrument, so it significantly cut down process time and inherent costs.

Q Why did you decide to use Haydon actuators?

I have been using Haydon's LC15s, your smallest Ø15mm linear actuators since 2006, and was familiar with your proactive response at the design phase. Haydon provided the right information, early on, without the need for me to search for it. So, when I was envisioning technical issues, Haydon was already supplying corresponding answers.

Q Among the 3 different Haydon actuators in use within the Novodiag, 2 required particular attention during the design phase. Can you tell me more about those?

The first actuator, a 19000 Captive, is used in a syringe pump. Such application requires the actuator to both perform high resolution motions for precise microfluidic dosing, and to push with enough force at various speeds, from low to high speeds, to help optimize the process times. What led me to select the 19000 Captive from Haydon was its capability to meet the previously mentioned specifications as well as its small footprint of only Ø20mm. Further customization like custom stroke, as well as the removal of the rear cover of the actuator to save space, further convinced me about the veracity of the actuator selection for this syringe pump. Despite searches, I could not find a market alternative which was able to meet the full criteria.

The second actuator is central within the Novodiag architecture. We named it the "pressing motor" because it presses our disposable (small cassette) against the active elements, notably the fluidic seals and the thermal contact surfaces. To perform such function, there is need for a high push force as well as the capability to stay in a precise position against this force to ensure perfect contact of all the elements. Along the development phase, I came to realize that not only such push force was to be quite high, but also that the actuator needed to perform it over a long period of time. So, we went to discuss this issue with Haydon and questioned what would happen if such actuator was driven outside of the datasheet limitations as a matter of current per phase, force, and resulting heat coming from the motor. Typically, our R&D team could have answered all these points by extended testing and efforts, but Haydon gave us an attentive ear and shared sufficient information about the actuator technology to improve confidence in selecting a 35000 Captive actuator. Because of the results of our performance and life tests, in correlation with a deep understanding of its intrinsic capabilities, this actuator is functioning perfectly even outside of its catalog standard specifications. To guarantee its performance, during the final quality check, Haydon tested 100% of them using a force test matching our system parameters. This allowed our own production to install it right away in our

sub-assembly, without the need to perform additional testing to pre-assembly operations. We would have not accepted a lower level of quality control from another supplier. Due to the technical requirement of the function "pressing", the actuator might have been a challenge to implement in our design, if we did not have the assistance and support of Haydon.

Q Based on your experience, if something needs improvement for your next instrument design project, what would it be?

From a development point of view, I can always repeat the normal conditions inherent to a given system, and I can validate technical choices only after several campaign of various tests. As research and development costs will increase when a thorough research of the best solution is becoming a necessity, costs will drastically increase when supplier's information is insufficient and creates the need for extended tests of multiple solutions to end up with a proper design. When the development process accelerates, finding transparent answers and solutions to encounter problems is what we need from a supplier. Haydon plainly embraces this role, and with honesty has been an asset for Mobidiag.

Q What is the main criteria in your supplier selection?

As an IVD manufacturer, Mobidiag has high quality requirements on our instruments and disposables. This translates into critically selecting our suppliers based on the level of quality their products are showing as well as compliance to industry standards like ISO 9001 and others. ■

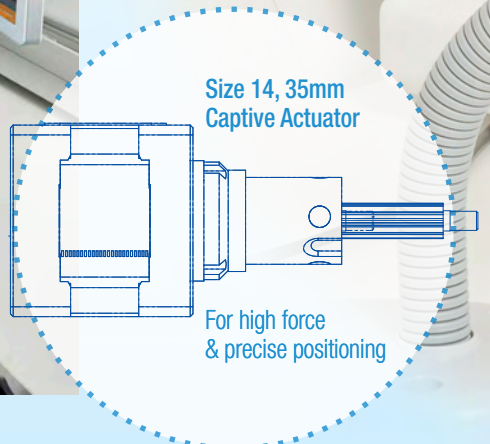

Now Available ▶

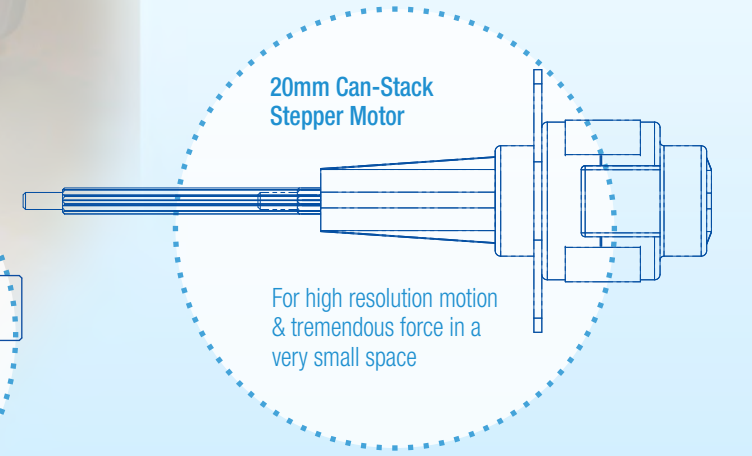
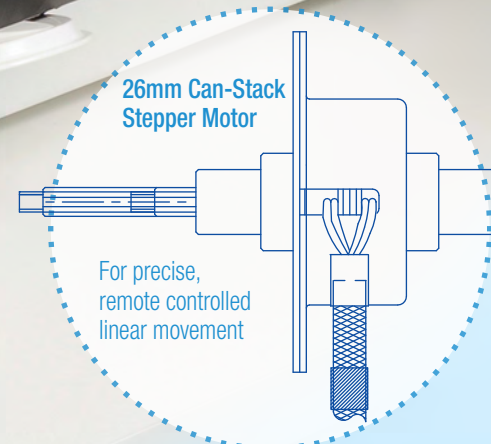

“In all honesty, Haydon's know-how allowed us to gain a lot of time during the development phase.”

– Regis Melizzi,
Instrument Team Manager
at Mobidiag

Now Available ►

The Novodiag® platform combines high quality and affordable costs, allowing widespread use both in mass screening and on-demand highly targeted or syndromic tests for various infectious diseases.

Mobidiag is a certified in-vitro diagnostics medical device manufacturer with distributors in Europe, the Middle East and Africa. Following the joint venture with the Chinese leader in diagnostics, Autobio Diagnostics, Mobidiag will offer its Novodiag solution in China.

MOBIDIAG



Together Stronger, Fighting COVID-19

*Effective May 1, 2020, Novodiag® COVID-19 test has been granted emergency use authorization for Finland (and soon upcoming in France, UK and Sweden).



Haydon Kerk Pittman
AMETEK Advanced Motion Solutions

1500 Meriden Road
Waterbury, CT 06705 USA
www.haydonkerkpittman.com

